

Intelligent display instrument  
**APOSYS 02 - xx - x - x**

**TECHNICAL DOCUMENTATION**



Producer:

**APOELMOS**  
**measurement & control**

**A.P.O. – ELMOS v.o.s.**

**Pražská 90, 509 01 Nová Paka**

**Czech Republic**

**tel.: +420493 504 261, fax: +420493 504 257**

**e-mail: apo@apoelmos.cz**

**http://www.apoelmos.cz**



1



ISO 9001

may 2005, TD-U-04-01

## 1. Introduction

APOSYS 02 is intelligent 4 points display instrument controlled by microprocessor with possibility of signalling 2 limit values.

## 2. Description

### 2.1 *Front panel*

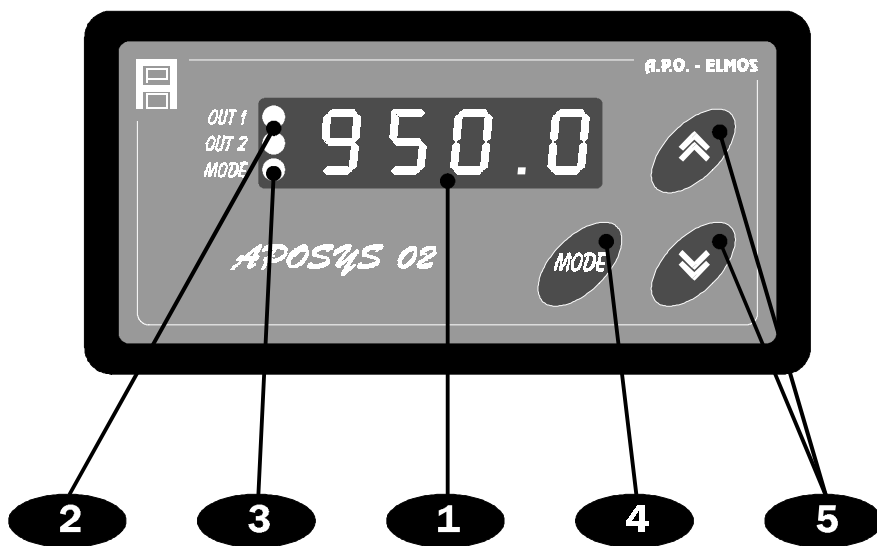

#### 1 - Display

Display shows measured value. At parameters programming the display provides lucid report.

#### 2 - The check lights of outputs state

The check lights „OUT1“ and „OUT2“ 4 indicate the state of outputs relays by this way: the check light is lighting – output is switch-on, the check light don't lights – output is switch-off.

#### 3 - – The check light „MODE“

The check light „MODE“ indicate presence in the programming menu.

#### 4 - Key „MODE“

Key „MODE“ is for input to programming of parameters and for confirmation of setting dates.

#### 5 – Setting keys

Keys are for listing in a parameters selection and for numbers dates setting at programming. At the key keeping the listing or setting run faster. When you press both keys at same time the setting parameter is deleted.

## 2.2 Input part

On inputs terminals blocks of the instrument is possible to connect the sensor Pt100, Ni1000/6180ppm, resistive temperature transmitter Mesit (P1-8, LUN 1356-8 till LUN 1358-8 with resistance  $0^{\circ}\text{C} = 90,1\Omega$  and  $100^{\circ}\text{C} = 129,8\Omega$ ), thermocouple (J, K, E, T, R, S), current signal (4-20 mA, 0 - 20 mA) or voltage signal (0 - 10 V). Changes of a type of the input signal is possible achieve by apparatus keypad or by program PA 02a. From production is the instrument set to input value which is shows in the chart of limit values on page 14.

## 2.3 Output part

Output elements are two miniature relays with max. loading 250 VAC, 2 A. Relay contacts are protected by varistors. For switching of inductive loading is recommended ,for increase of reliability and decrease of interference, to connects for corresponding contacts anti-jamming RC networks (for example  $0,1\ \mu\text{F} + 220\ \text{K}$ ).

**Warning:** Connected varistors are defined for max. working voltage 250 Vef. At switching some motors in a single-phase connecting with a capacitor, for phase shift, can make it on winding connected through the capacitor permanent increasing the working voltage over setting of value allowable varistors voltage.

## 2.4 Signalling

The instrument is equip with the function of signalling of 2 limits values. For both values is possible to select the function (on/off after overrun of the required value). Both eventual states are demonstrate on the diagram:

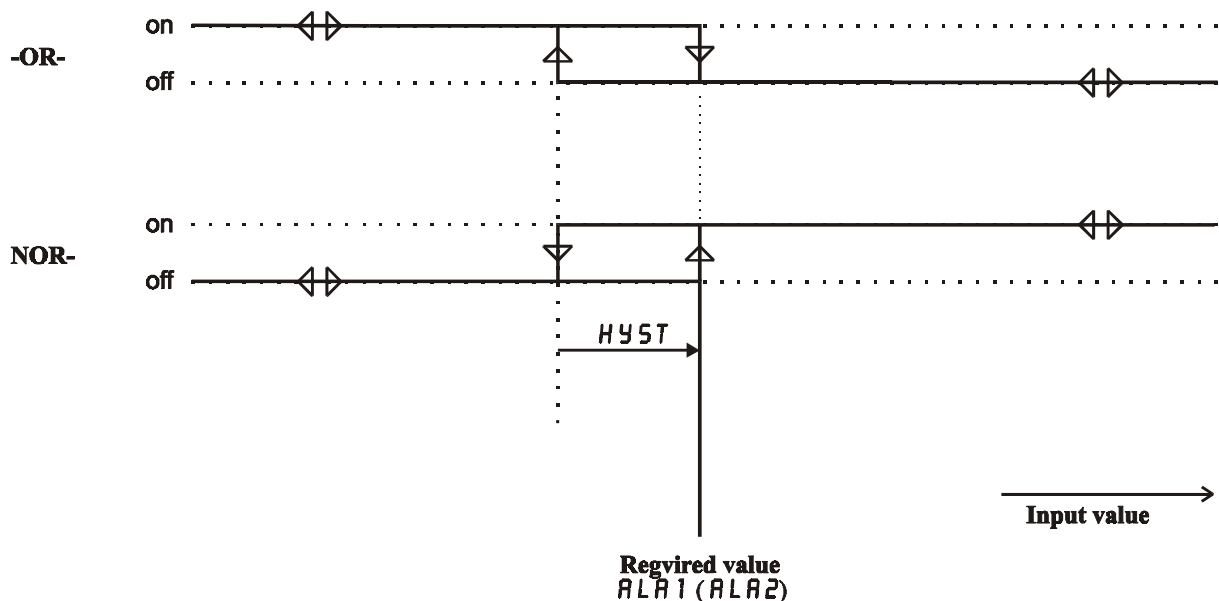

## 2.5 Technical dates

Power supply	APOSYS 02-xx-1=1/N/PE - 230 VAC(+10 -15%) 50Hz APOSYS 02-xx-2= 24 VDC (+10 -15%) APOSYS 02-xx-3= 24 VAC (+10 -15%) 50Hz
Power input	max. 5 VA
Fuse	for power supply 230VAC - 0,05A (T 50 mA) for power supply 24VDC – 1,25A (T 1,25 A) for power supply 24VAC - 0,63A (T 630 mA)
Display	-999 ~ 0 ~ 9999 red 4 point LED with high intensity of light or green 4 point LED with high intensity of light height of marks 10 mm
Decimal point	setting by program
Input signal:	
sensor Pt100 by DIN IEC 751/A2	-80 ~ 800°C
sensor Ni1000/6180ppm	-50 ~ 200°C
thermocouple „J“	-200 ~ 1200°C
thermocouple „K“	-200 ~ 1300°C
thermocouple „E“	-200 ~ 1000°C
thermocouple „T“	-200 ~ 400°C
thermocouple „R“	-50 ~ 1700°C
thermocouple „S“	-50 ~ 1700°C
current signal	4 ~ 20 mA, 0 ~ 20 mA
voltage signal	0 ~ 10 V, 0 ~ 70 mV
resistive temperature transmitter MESIT	-50 ~ 300°C („P1-8, LUN 1356-8, LUN 1357-8, LUN1358-8“ measuring accuracy 0,5%)
Compensation of thermocouples comparison ends :	
Inner	accuracy 0,5°C at temp. 20°C temperature coefficient 50ppm/°C
outer	20°C, 50°C or 70°C setting by program
Outputs:	
switching	2x relay 250 VAC, 2 A
data	RS 485, bidirectional communication, speed 9600 Baud 11 transmission bits, communication master-slave
Temperature coefficient	25 ppm/°C
Measuring accuracy	±0,15 % from range ±1 digit
Speed	3 measurement per second
Resolution	by decimal point state, max. 0,01
Calibration	at 25°C and 40 % r.h.
Data redundancy	electrically (EEPROM)
Type of apparatus	panel
Dimensions	96 x 48 x 119 mm
Mounting hole in panel	90,5 x 43,5 mm (with holes Ø 3 mm in angles)
Keyboard	foil 3 keys
Weight	0,4 kg

Operating temperature	0 ~ 60 °C
Steady time	to 5 min after switch-on
Coverage	IP 54 (front panel)
Bonding	terminal block (max. section 2,5 mm <sup>2</sup> )
Source	for power supply of the sensor up to 25 mA
<b>Electromagnetic Compatibility</b>	ČSN EN 50081 – 2 ČSN EN 50082 – 1
<b>Seismic proof</b>	ČSN IEC 980:1993, čl.6

## 2.6 Dimensions

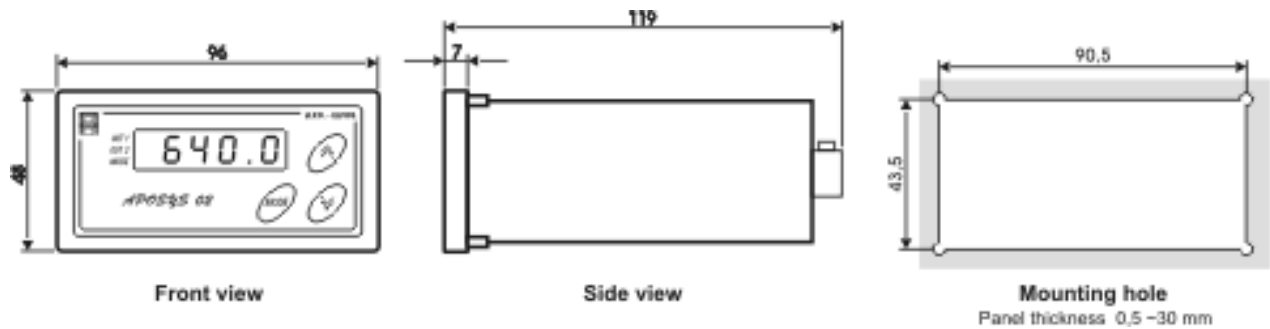

## 2.7 Mounting instructions

The controller handle in the mounting hole with help two holders.

Wires are connected to screw connectors on the rear panel of the controller. Connectors are as 3 single taking down construction blocks: connector 1 - 6 - block of inputs and c communication, connector 7 - 10 - block of relays outputs , connector 11, 12 - block of power supply. Every block of connectors is possible to take down back from the controller. Wires are possible to connect to taking down blocks and then connect all blocks to the controller.

## 2.8 Apparatus connecting

Switch or trip switch must be:

- building installation components
- in immediate apparatus neighbourhood
- operator accessible
- tagged as isolating system element

### **WARNING:**

If you use this apparatus by another way than define producer could be the protection provided by apparatus corrupted.

## 2.9 Connecting of terminal block

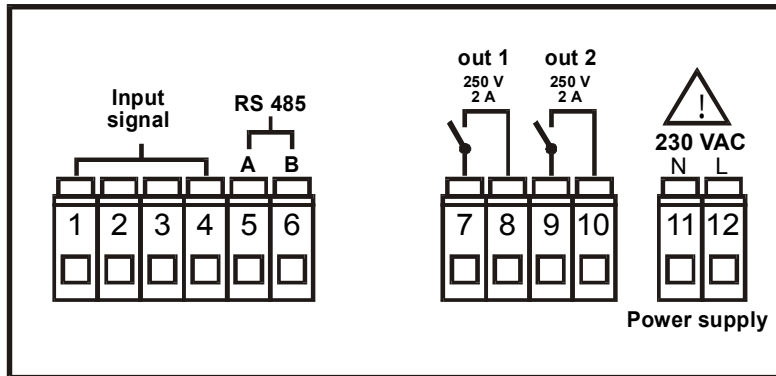

### Inputs signale

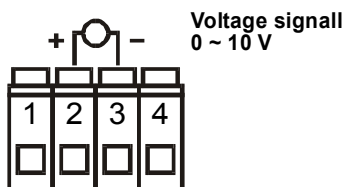
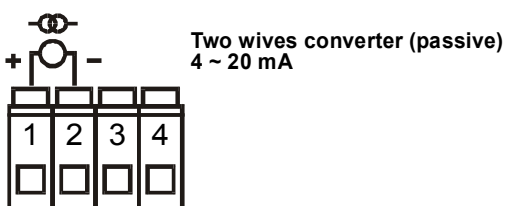
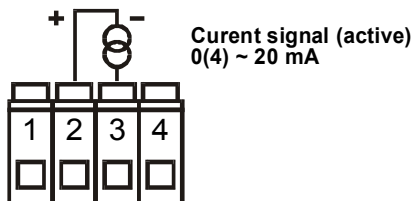
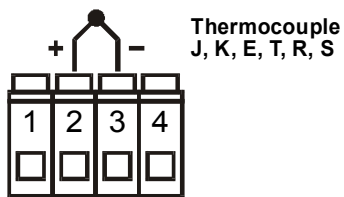
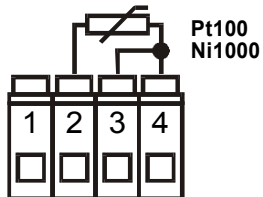

### **WARNING:**



*Hazard alarm (attention for supply voltage).*

## 2.10 Measure ranges of inputs quantities

Type	Range
Sensor Pt100	-80 ~ 800°C
Sensor Ni1000/6180 ppm	-50 ~ 200°C
Thermocouple J	-200 ~ 1200°C
Thermocouple K	-200 ~ 1300°C
Thermocouple E	-200 ~ 1000°C
Thermocouple T	-200 ~ 400°C
Thermocouple R	-50 ~ 1700°C
Thermocouple S	-50 ~ 1700°C
Current signal 4 ~ 20 mA	Optional
Current signal I 0 ~ 20 mA	Optional
Voltage signal 0 ~ 10 V	Optional
Resistive temperature transmitter P1-8, LUN 1356-8, LUN 1357-8, LUN 1358-8	-50 ~ 300°C

## 2.11 Inner inputs connecting

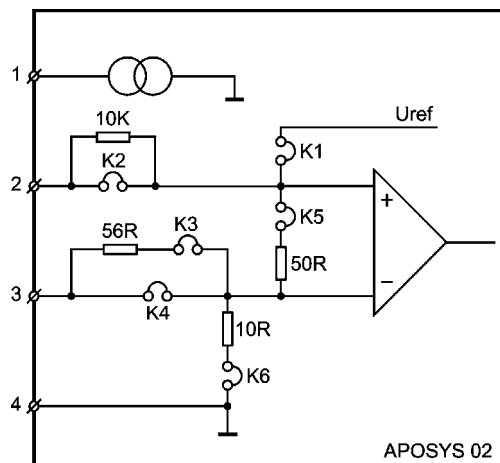

## 2.12 Example of threewires current sensor 4.. 20 mA connecting

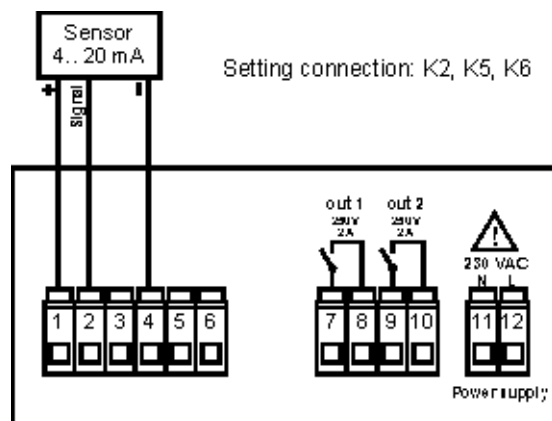

## 2.13 Connecting of interface field

In the interface field is necessary to set by delivered bonds the type of elect input signal optionally lockout of dates or ending of communication line RS 485. The interface field is allowable after extraction of bonds 1 - 6.

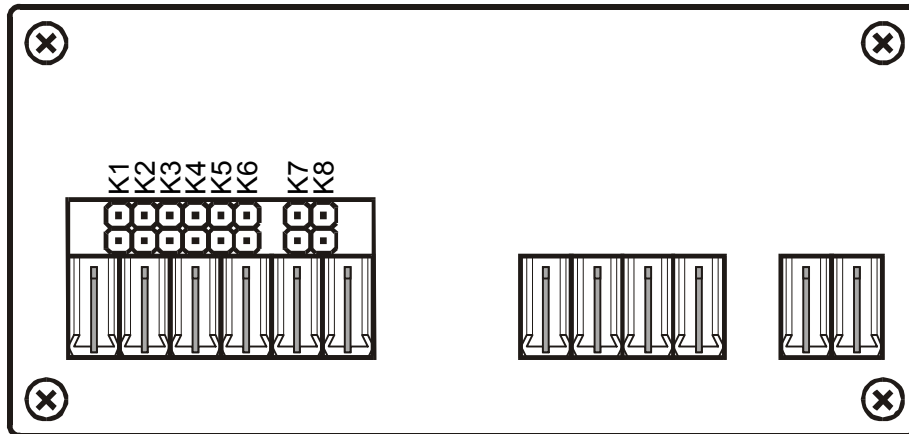

**Option of bonds setting:**

Type	Bonds adjusting
Sensor Pt100	K1, K2, K3
Sensor Ni1000/6180 ppm	K1, K2, K3
Thermocouple J, K, E, T, R, S	K2, K4
Current signal 4 ~ 20 mA (passive)	K2, K5, K6
Current signal 0(4) ~ 20 mA (active)	K2, K4, K5
Resistive temperature transmitter P1-8, LUN 1356-8, LUN 1357-8, LUN 1358-8	K1, K2, K3
Voltage signal 0 ~ 10 V	K4, K5
Lockout of dates	K7
Ending of line RS 485	K8

At selecting of the type of inputs signal by program PA 02 is necessity to respect the setting of the interface field .

### 3. The programming

In the programming mode is possible to set optional parameters of the controller. For using of the controller is necessity to adapt the controller to concrete user application by setting of the required parameters. Standard values are in the programming mode setting by producer. And they are show in a limit values chart (page 14). After program escape in the menu END by key MODE will dates writing run over.

As long as in the programming course do not be pressed the arbitrary key during 1 minute the controller automatically come over to main menu without setting parameters record (function TIME OUT).

#### **Warning !**

Before programming is necessity to check if is taking out the bond K7-for lockout of dates. After finish of programming is possible to protect parameters against overwriting by setting of bond K7, this means that parameters is possible to change at discretion, but after break-and-make of power supply appears parameters set before interdict of overwriting.

### 3.1 Meaning of parameters

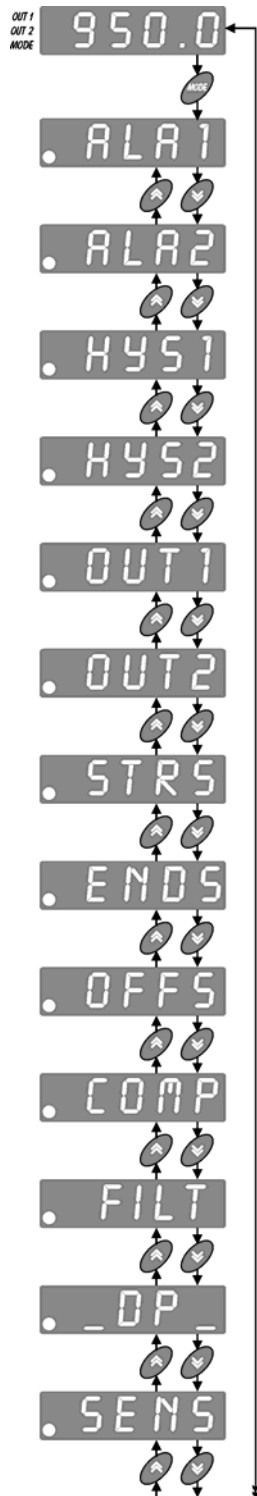

#### Operating menu

By the key „MODE“ press you enter to programming.

#### ALA1

limit value for output out1

#### ALA2

limit value for output out2

#### HYS1

hysteresis of switching for output out1

#### HYS2

hysteresis of switching for output out2

#### OUT1

function of output out1 (-OR- after achievement of limit switch-off, -NOR after achievement of limit switch-on)

#### OUT2

function of output out2 (-OR- after achievement of limit switch-off, -NOR after achievement of limit switch-on)

#### STRS

beginning of the measuring range (start sensor), valid only for current and voltage signals. For resistive and thermocouple sensors it is not shows

#### ENDS

end of the measuring range (end sensor), valid only for current and voltage signals. For resistive and thermocouple sensors it is not shows

#### OFFS

shift of measured value

#### COMP

type of thermocouple compensation – valid only for thermocouple! (-NO- without compensation, TS-- compensation for temperature of clamps, 20, 50 or 70 °C)

#### FILT

integrating filter for suppression of input signal changes

#### \_DP\_

decimal point position

#### SENS

type of input signal:

_ _ J _	thermocouple „J“
C R A L	thermocouple „K“
_ _ E _	thermocouple „E“
_ _ T _	thermocouple „T“
_ _ R _	thermocouple „R“
_ _ S _	thermocouple „S“
_ P T _	sensor Pt100
N I _ 5	sensor Ni1000/6180ppm

4_20	CURRENT signal 4 - 20 mA
0_20	CURRENT signal 0 - 20 mA
0_10	voltage signal 0 - 10 V
RESI	resistive sensor

**At selecting of the type of inputs signal is necessity to respect the setting of the interface field (see connecting of interface field page **Chyba! Záložka není definována.**).**

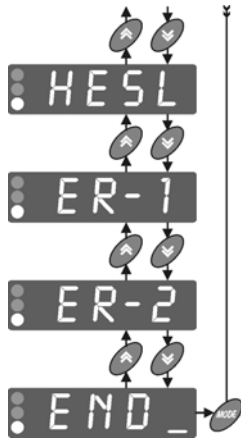

#### **HESL**

access code – from production is set „0“. This means that access to programming mode is not under a password. If you set a arbitrary number password, this will be required always at access to programming. At ignorance of the password is possible to access to code „555“.

#### **ER-1 (ER-2)**

state of the output relay 1(2) at failure of input sensor  
(-OFF = at failure is the output switch-off, -ON- = at failure is the output switch-on)

by press of the key „MODE“ you will finish the programming.

**Attention for TIME OUT function.** At TIME OUT function will not save set parameters in the programming mode.

## 4. Parameters limit values

Code	Importance	Limit values	From production
ALA1	limit value 1	-999 to 9999	0.0
ALA2	limit value 2	-999 to 9999	0.0
HYS1	switching hysteresis output 1	0 to 9999	0.0
HYS2	switching hysteresis output 2	0 to 9999	0.0
OUT1	output 1 function	-OR-, -NOR	-OR-
OUT2	output 2 function	-OR-, -NOR	-OR-
STRS	beginning of measurement range	-999 to 9999	
ENDS	end of measurement range	-999 to 9999	
OFFS	offset	-999 to 9999	0.0
-DP-	decimal point	0., 0.0, 0.00	0.0
SENS	sensor type	thermocouple J,K,E,T,R,S Pt100 Ni1000/6180ppm 4 to 20 mA 0 to 20 mA 0 to 10 V resistive temperature transmitter P1-8, LUN 1356-8, LUN 1357-8, LUN 1358-8	
CoMP	type of thermocouple compensation	NO, temp. of clamps, 20°C, 50°C, 70°C	temp. of clamps
FILT	integrating filter	0 to 10	0
HESL	access password	-999 to 9999	0
ER-1	output relay 1 state at sensor failure	-OFF, -ON-	-OFF
ER-2	output relay 2 state at sensor failure	-OFF, -ON-	-OFF

**The input sensor setting from the production** .....

**The chart of failure sates**

The instrument is provide with failure states signalling. At the sensor failure is possible in the menu ER-1 (ER-2) select the output relays state (-OFF = switch-off, -ON- = switch-on).

Type of sensor	signalling E ---	signalling E ---
Pt100, Ni1000	short circuit of sensor	disconnection of sensor
Thermocouple J, K, E, T, R, S	-	disconnection of sensor
0 ~ 20 mA	-	> 22 mA
4 ~ 20 mA	< 3 mA	> 22 mA
0 ~ 10 V	-	> 10,5 V

## 5. The communication protocol description

Communication protocol agree with protocol PROFIBUS layer 2. Data part (layer 7) implemented the protocol.

Communication is of the type **master - slave** and enable the two-ways communication between stations. The communication use the interface RS 485.

### Telegram mark (UART - Character)

Protocol:

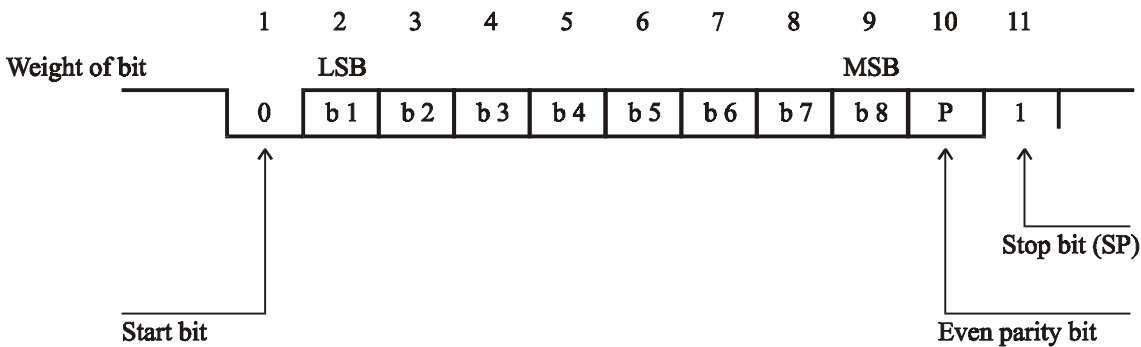

Every UART – character have 11 bits, and so 1 th start-bit (ST) with signal logic "0", 8 inform bits (I), 1 parity bit for even parity (P) with signal logic "1" and 1 stop-bit (SP) with signal logic "1".Transmit speed is 9600 Bd.

### Communication conditions:

Communications are initiate by superior communication participant on a principle request - answer. This principle allows addition of bigger numbers of participants to superior system on the interface RS-485. Controllers and sensors work as a slave participant .

From time aspect is necessary to keep following conditions:

- a) among single bits transmit from superior system have to be **shorter** delay than treble of a time necessary for transmit of the one bit.
- b) among received answer and transmitted next message have to be rest on the line **longer** than treble of a time necessary for transmit of the one bit.
- c) If the receive side detect a defect of link protocol (frame error, parity error, impassableness link, breach of listed above conditions),or a failure in the communication protocol (failure start parity mark, or finish mark, length of a telegram), the receive side the message unwork and not even answer. In a case of non-performance request for transmission or for logging (the instrument contains no dates), failure message is transmitted with SD1 and FC = 2 (negative confirmation).
- d) among last bit of the transmitted message and the first bit of the received answer is delay at minimum same as the time necessary for transmit of one bit..

## LAYER 2

### Formats of telegrams with compact length without data pole:

a) question

SD1	DA	SA	FC	FCS	ED
-----	----	----	----	-----	----

b) answer

SD1	DA	SA	FC	FCS	ED
-----	----	----	----	-----	----

### Format of telegrams with compact length

Telegram starts with SD1 and FC=0x69 and finish by finish mark ED.

Positive answer is the telegram with compact length with FC=0. Negative answer FC=2.

### Example of setting format of telegram with compact length without dates pole:

REQUEST	Number of transmitting marks:6
10 02 04 69 6F 16	
ANSWER	Number of receiving marks: 6
10 04 02 00 06 16	

### Formats of telegrams with variable length of information pole:

a) question

SD2	LE	LEr	SD2	DA	SA	FC	DATA	FCS	ED
-----	----	-----	-----	----	----	----	------	-----	----

b) answer

SD2	LE	LEr	SD2	DA	SA	FC	DATA	FCS	ED
-----	----	-----	-----	----	----	----	------	-----	----

### Importance of used symbols

<b>SD1</b>	frame start (Start Delimiter), code 10H
<b>SD2</b>	frame start (Start Delimiter), code 68H
<b>LE</b>	length of the information pole (Length) start by bit DA and finished by bit before
	FCS.
	Length of pole 4 - 249.
<b>LEr</b>	repeating of bit length of the information pole (Length repeat)
<b>DA</b>	address of target station (Destination Address)
<b>SA</b>	address of supply station (Source Address)
<b>FC</b>	drive bit (Frame Control)
<b>DATA</b>	pole of dates max 246 bits
<b>FCS</b>	control sum (Frame Check Sum)
<b>ED</b>	frame end (End Delimiter), code 16H

### LE, LEr – Length of information pole

Both bits in the head of telegram with variable length of information pole contents numbers of bits of information pole. In this is count DA, SA, FC and DATA. Upper value LE is 4, highest 249. By this possible to transmit 1 - 246 bits of dates.

### DA, SA – Address of the station (DA - target, SA - supply)

Addresses can be in the range 0 - 126, here at the address 127 is use as global address for transmitting of messages for all stations. At setting of global address the instrument receive only (do not transmitting). In the corresponding telegram is the target address (DA) exactly the supply address (SA) from calling telegram.

Limitation: Maximal setting address is 126. Controllers and sensors can not increase the address by bits EXT, how is definite in PROFIBUS.

## FC - Driving bit

Driving bit in the head of frame contents the transmit function and information to prevent for loss or doubling of message.

b8	b7	b6	b5	b4	b3	b2	b1
RES	1	FCB	FCV	FUNCTION			
	0	Stn - Type					

RES - reservation

**b 7 = 1** – frame of call (Send / Request)

FCB (Frame Count Bit): 0/1 – alternated bit of sequence of calls

FCV (Frame Count Bit Valid): 0 - function FCB unvalid  
1 - function FCB valid

Controllers and sensors do not use alternating bit FCB at FCV = 1, these bits have to have the value FCB=1 and FCV=0.

**FUNCTION:** frame of call b7 = 1

code	function
<b>0x03</b>	Send Date with Acknowledge Data sending with acknowledgement
<b>0x09</b>	Request FDL - Status With Reply Request for Status
<b>0x0C</b>	Send and Request Data Sending and request for dates

**b7 = 0 - frame of acknowledgement or answer** (Acknowledgement/Response)

Stn - Type (Station type and FDL - STATUS) - to characterise the type of a participant.

Only passive participant  $\Rightarrow$  b6 and b5 = 0.

**FUNCTION:** frame of answer b7 = 0

code	function
<b>0x00</b>	Acknowledgement positive positive acknowledgement
<b>0x02</b>	Acknowledgement negative Negative acknowledgement
<b>0x08</b>	Response FDL / FMA - Date data transmitting

### FCS - control sum

Control sum is done with arithmetic data sum of information frame DA, SA, FC and DATA module 256 (100h) with ignore of higher ranks creation by transfer 256 (100h).

$$25h = (24h + 30h + 37h + 52h + 48h) \text{ MOD } 100h$$

$$\text{For SD1 } \sum_{\substack{\text{FC} \\ \text{DA}}} \text{ mod } 256 \qquad \text{for SD2 } \sum_{\substack{\text{FCS-1} \\ \text{DA}}} \text{ mod } 256$$

### Format of telegrams with variable length of information pole

Telegram start with SD2 and FC=0x6C. And finish with ending mark ED.

Positive answer is telegram with compact length with FC=0. Negative answer FC=2.

```
REQUEST                               Number of transmitting marks:13
68 07 07 68 02 04 6C 01 00 07 00 7A 16

ANSWER                               Number of receiving marks:   11
68 05 05 68 04 02 08 81 01 90 16
```

## LAYER 7

Layer 7 (PROFIBUS data part) implement the protocol. There are these services:

- 1) **Reading of the instrument identification**
- 2) **Reading of firmware version**
- 3) **Reading of a value**
- 4) **Record of a value**
- 5) **Reading of the instrument state**
- 6) **Reading and record of synchronising dates**

### 1) Reading of the instrument identification – Identify

telegram SD2 data part

a) request

SD2	LE	LEr	SD2	DA	SA	FC	RI	FCS	ED
-----	----	-----	-----	----	----	----	----	-----	----

FC		0x6C
RI	REQ_IDENTIFY	0x00

b) answer

SD2	LE	LEr	SD2	DA	SA	FC	DATA	FCS	ED
-----	----	-----	-----	----	----	----	------	-----	----

FC		0x08
DATA	Name type	21 byte

### 2) Reading of firmware - Version

telegram SD2 data part

a) request

SD2	LE	LEr	SD2	DA	SA	FC	RV	FCS	ED
-----	----	-----	-----	----	----	----	----	-----	----

FC		0x6C
RV	REQ_VERSION	0x04

b) answer

SD2	LE	LEr	SD2	DA	SA	FC	DATA	FCS	ED
-----	----	-----	-----	----	----	----	------	-----	----

FC		0x08
DATA		



### 5) Reading of the instrument state

telegram SD2, data part

a) request

<b>SD2</b>	<b>LE</b>	<b>LEr</b>	<b>SD2</b>	<b>DA</b>	<b>SA</b>	<b>FC</b>	<b>RU</b>	<b>FCS</b>	<b>ED</b>
------------	-----------	------------	------------	-----------	-----------	-----------	-----------	------------	-----------

FC 0x6C

RU REQ\_Unit\_Status 0x03

b) answer

<b>SD2</b>	<b>LE</b>	<b>LEr</b>	<b>SD2</b>	<b>DA</b>	<b>SA</b>	<b>FC</b>	<b>DATA</b>	<b>FCS</b>	<b>ED</b>
------------	-----------	------------	------------	-----------	-----------	-----------	-------------	------------	-----------

FC 0x08

DATA controller state 5 bits

<b>4 bit</b>	<b>1 bits</b>
<b>measured value</b> (float)	<b>OUT</b> (char)

OUT bit = 0 output relay is switch-off

OUT bit = 1 output relay is switch-on

measured value = float format

OUT bit D0 represent output 1

bit D1 represent output 2

### 6) Reading and record of synchronising dates

Telegram SD2, data part.

a) request

<b>SD2</b>	<b>LE</b>	<b>LEr</b>	<b>SD2</b>	<b>DA</b>	<b>SA</b>	<b>FC</b>	<b>RSS</b>	<b>FCS</b>	<b>ED</b>
------------	-----------	------------	------------	-----------	-----------	-----------	------------	------------	-----------

FC 0x63

RSS REQ\_SYNCHRO\_SAMPLING 0x05

b) answer after instruction REQ\_SYNCHRO\_SAMPLING with FC=0x63 achieve the draft of measured value to buffer. Positive acknowledgements (SD1, FC = 0), in a case of a failure (FC = 2). At using the global address DA=127 is not any answer, the instrument achieve the draft of measured dates only.

c) answer after instruction REQ\_SYNCHRO\_SAMPLING with FC=0x6C

SD2	LE	LEr	SD2	DA	SA	FC	<b>RES Measured value</b>	FCS	ED
-----	----	-----	-----	----	----	----	---------------------------	-----	----

<b>1 bit</b>	<b>4 - bits</b>
<b>RES</b>	<b>measured value (float)</b>

```
# define FC 0x08
#define RES 0x01 indicate first draft
#define RES 0x00 indicate, one read dates at least
```

### Importance of use symbols

```
# define REQ_IDENTIFY 0x00 request on the identification
# define REQ_READ 0x01 request for data sending
# define REQ_WRITE 0x02 request for data record
# define REQ_Unit Status 0x03 request on the instrument state
# define REQ_VERSION 0x04 request on the firmware version
# define REQ_SYNCHRO_SAMPLING 0x05 request on the synchronous draft
```

Tabulka 1

Chart_nr. TC = 1				
Importance	Code	Range	type	Number of bits
alarm 1	ALA1	-999 to 9999	float	4
alarm 1	ALA2	-999 to 9999	float	4
hysteresis 1	HYS1	0 to 9999	float	4
output inverting 1	OUT1	0 / 1	char	1
output inverting 2	OUT2	0 / 1	char	1
relay state at sensor failure	ER-1 / ER-2	0x00 / 0x01 0x10 / 0x11	char	1
hysteresis 2	HYS2	0 to 9999	float	4

```
OUTx          0 = OR          1 = NOR
ER-1          bit D0 = 0 relay 1 off      bit D0 = 1 relay 1 on
ER-2          bit D4 = 0 relay 2 off      bit D4 = 1 relay 2 on
```

Chart 2

Chart_nr. TC = 2				
Importance	code	range	type	Number of bits
Begin of range	STRS	-999 to 9999	float	4
End of range	ENDS	-999 to 9999	float	4
Offset	OFFS	-999 to 9999	float	4

Chart 3

Chart nr. TC = 3				
importance	code	range	type	Number of bits
Type of sensor		0 - 10	char	1
Compensation	COMP	0 - 4	char	1
Decimal point	DP	0 - 2	char	1
Filter	FILT	0 - 10	char	1
Password	HESL	-999-9999	int	2

**Sensor type**

0 = thermocouple "J"	6 = Pt100
1 = thermocouple "K"	7 = Ni1000/6180ppm
2 = thermocouple "E"	8 = 4 to 20 mA
3 = thermocouple "T"	9 = 0 to 20 mA
4 = thermocouple „R“	10 = 0 to 10 V
5 = thermocouple "S"	

**COM PENSATION**

- 0 = without compensation
- 1 = temperature of clamps
- 2 = temperature 20°C
- 3 = temperature 50°C
- 4 = temperature 70°C

**\_DP\_**

- 0 = number
- 1 = one decimal point
- 2 = two decimal points

**FILTER**            0 = no                    1-10 = yes

Chart 4

Chart nr. TC = 4				
importance	code	range	typ	Number of bits
Instrument address	-	0 - 126	char	1

After setting of the instrument address is the answer with the new address SA.

## Format of dates stored in APOSYS 02

### Signed and Unsigned Characters

Range of char type is 1 bit (8 bits). For example value 0x12

<b>Address</b>	<b>+0</b>
<b>Contents</b>	<b>0x12</b>

### Signed and Unsigned Integers

Range of int type is 2 bits (16 bits). For example value 0x1234

<b>Address</b>	<b>+0</b>	<b>+1</b>
<b>Contents</b>	<b>0x12</b>	<b>0x34</b>

### Signed and Long Integers

Range of long type is 4 bits (32 bits). For example value 0x12345678

<b>Address</b>	<b>+0</b>	<b>+1</b>	<b>+2</b>	<b>+3</b>
<b>Contents</b>	<b>0x12</b>	<b>0x34</b>	<b>0x56</b>	<b>0x78</b>

### Floating-point Numbers

Range of float type is 4 bits (32 bits) by standard IEEE-754

<b>Address</b>	<b>+0</b>	<b>+1</b>	<b>+2</b>	<b>+3</b>
<b>Contents</b>	<b>SEEE EEEE</b>	<b>EMMM MMMM</b>	<b>MMMM MMMM</b>	<b>MMMM MMMM</b>

**S** present mark (1 negative value and 0 positive value)

**E** „Two’s complement exponent“ with offset 127

**M** 23-bit normal mantissa

**Example: value -12,5 is declare hexadecimal 0xC1480000**

<b>Address</b>	<b>+0</b>	<b>+1</b>	<b>+2</b>	<b>+3</b>
<b>Contents</b>	<b>0xC1</b>	<b>0x48</b>	<b>0x00</b>	<b>0x00</b>

Notice:

**At first is emit the mark with address (address+0) and last is emit the mark with address (address+n).**

## **6. Instructions for software PA 02a installation**

### **6.1 Software APOELMOS application**

Hardware requirements:

PC: Pentium 100  
graphic card: VGA  
CD ROM Drive

Software requirements:

MS Windows 95/98/ME and higher versions.

Installation of software suppose the basic knowledge for working with PC and selected instructions MS Windows.

### **6.2 Installation processing:**

- 1) Insert CD ROM to CD ROM drive. If after CD ROM insert to CD ROM drive will start Internet Explorer (autorun) you select from concrete offer „Přístroje“ (Apparatuses), „Ukazovací přístroje“ (Display apparatuses). Select program for setting of display apparatus APOSYS 02 dates (see. Column – loading / installation sw)
- 2) On HDD you create a directory
- 3) Program save to the created directory on HDD.
- 4) Run file **Pa-02a.exe** .

### **6.3 Program PA 02a description**

- 1) Introduction
- 2) First startup
- 3) Graph setting
- 4) Data record speed setting
- 5) Controller parameters setting
- 6) Controller set parameters saving
- 7) Data record starting

## **7. Introduction**

Software is for controller set parameters and for measured values monitoring.

### 7.1.1 First startup

After software starting you have to set the communication line and the controller address first. In the menu setting you click on the key communication port. The window - communication port is open. At first you set the serial line and communication speed 9600Bd. After that you click on the key – find addresses. In the address chart is displayed the controller address which you enter to the apparatus address. The PC address can be arbitrary in the range from 0 to 126. After setting you confirm by key OK.

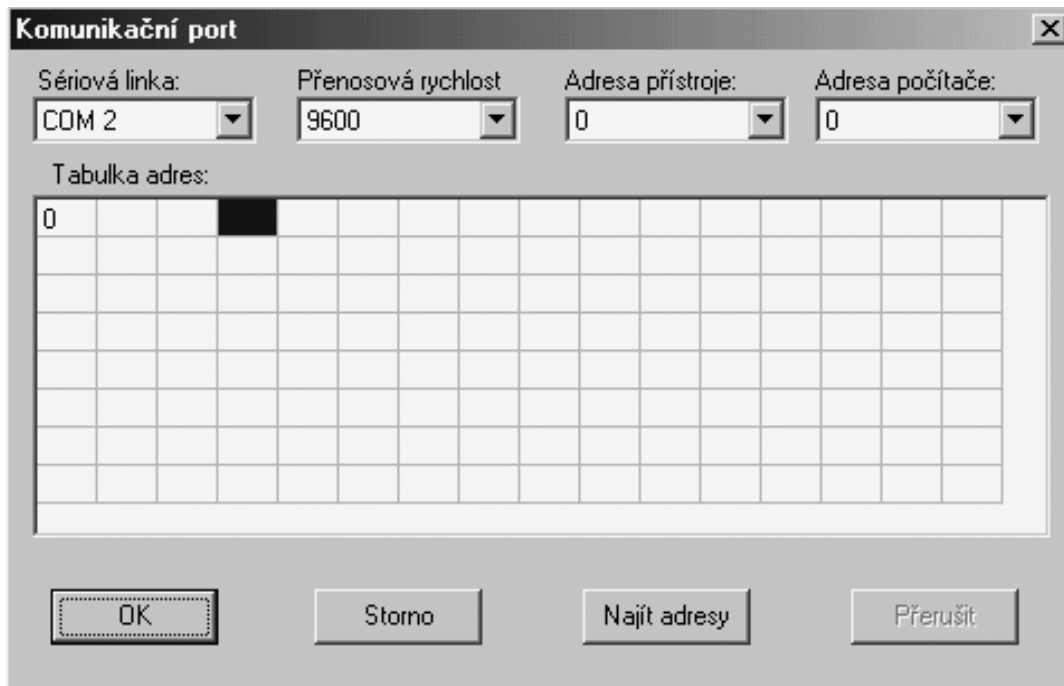

### 7.1.2 Graph setting

In the menu setting you click on the key graph setting. The window is open. You set the required range and the time axis of the graph.



### 7.1.3 Data record speed setting

In the menu setting you click on the key - data record speed. The window - data record speed is open. Here you set the required speed of storing to the form and the time of the automatic form storing to the file.

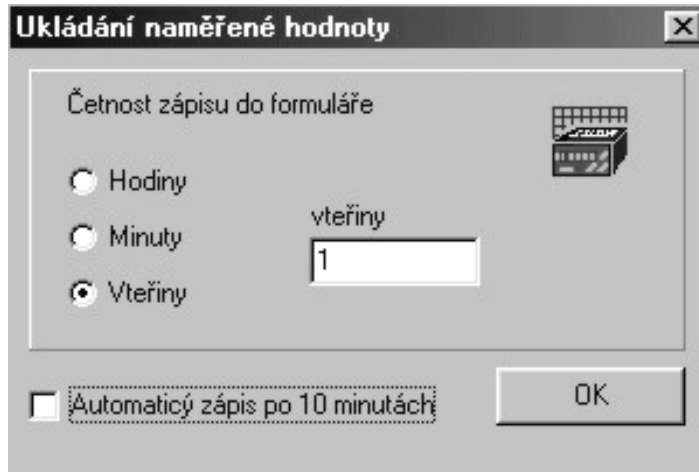

Ukládání naměřené hodnoty

Četnost zápisu do formuláře

Hodiny

Minuty

Vteřiny

vteřiny

1

Automatický zápis po 10 minutách

OK

### 7.1.4 Controller parameters setting

In the menu setting you click on the key - controller setting. The window - APOSYS 02 data is open. By the key – parameters reading you can read parameters from the controller. But only parameters which contain the active card. By the key - parameters writing you can write parameters from the active card to the controller. After parameters setting of the controller you click on the key „Parameters writing“ for parameters save in the controller in the case of power failure of the controller.

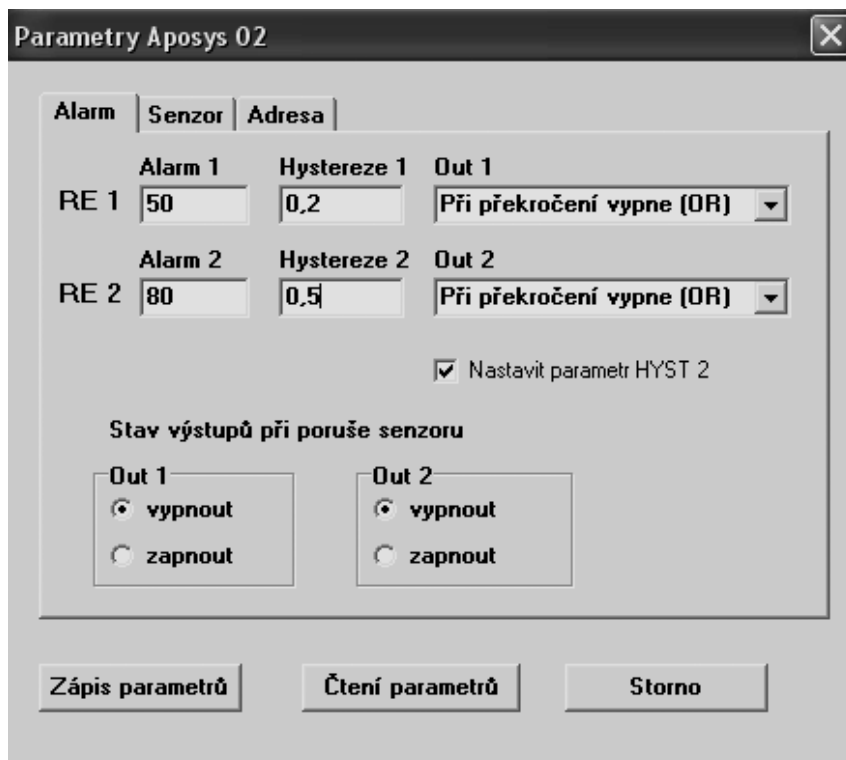

Parametry Aposys 02

Alarm | Senzor | Adresa

Alarm 1    Hystereze 1    Out 1

RE 1    50    0,2    Při překročení vypne (OR)

Alarm 2    Hystereze 2    Out 2

RE 2    80    0,5    Při překročení vypne (OR)

Nastavit parametr HYST 2

Stav výstupů při poruše senzoru

Out 1

vypnout

zapnout

Out 2

vypnout

zapnout

Zápis parametrů    Čtení parametrů    Storno

### 7.1.5 Controller set parameters saving

In the window APOSYS 02 you can save the set parameters to the file by the key „Save“ (uložit). The file have the suffix txt.

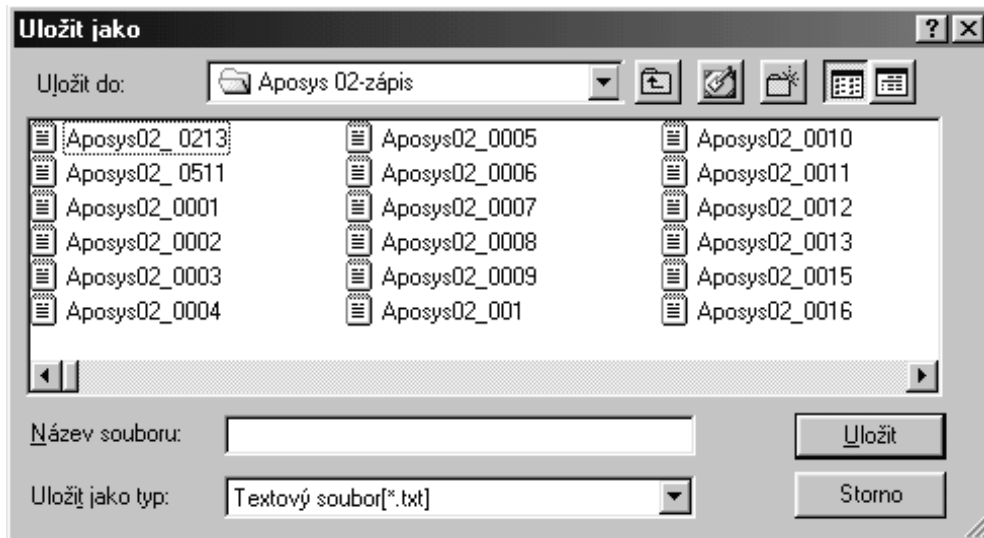

### 7.1.6 Data record starting

In the main window is start and stop of data record starting.

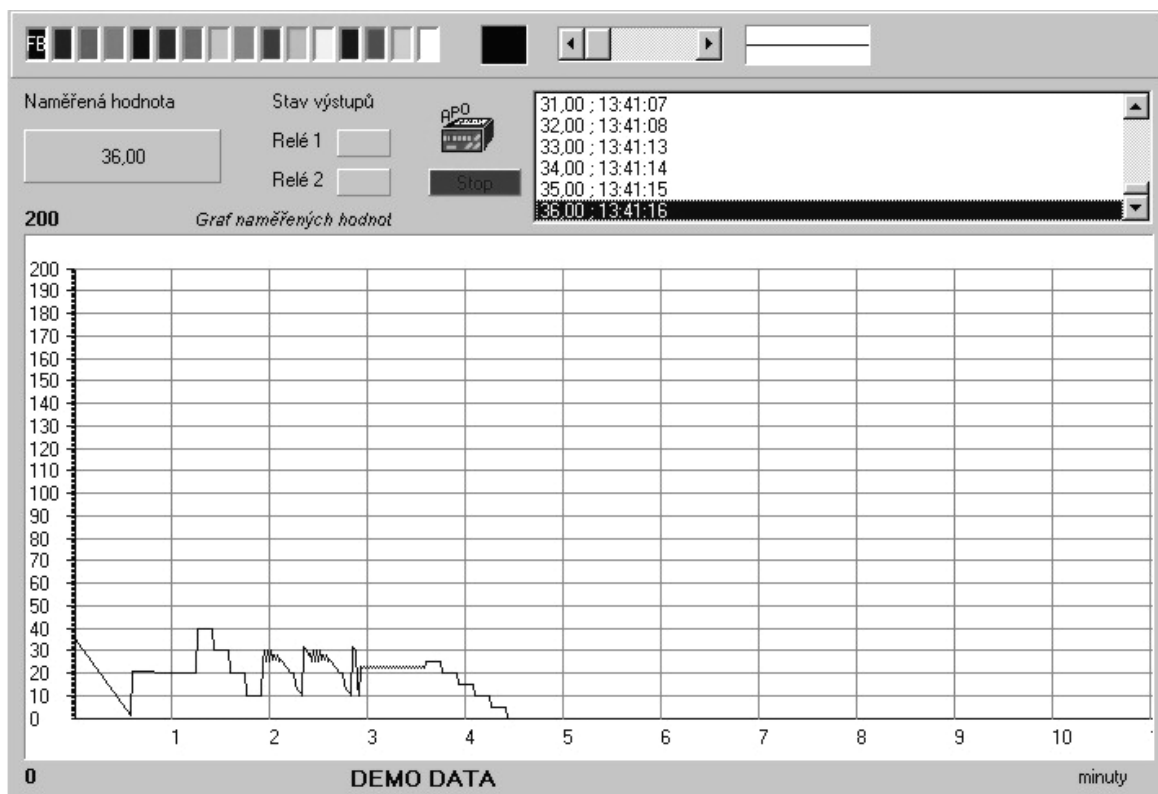

## 7.2 Apparatus connection with PC

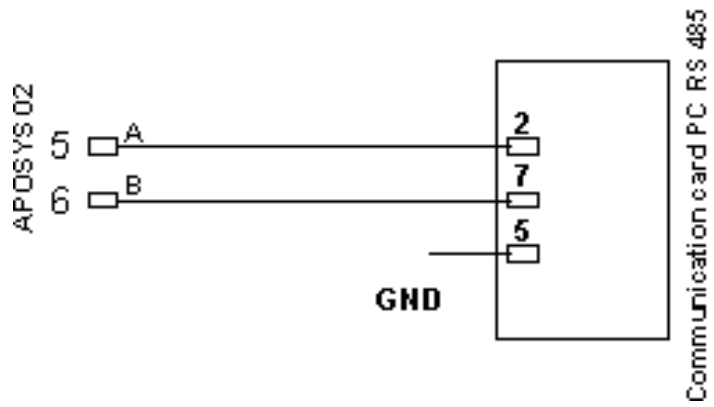
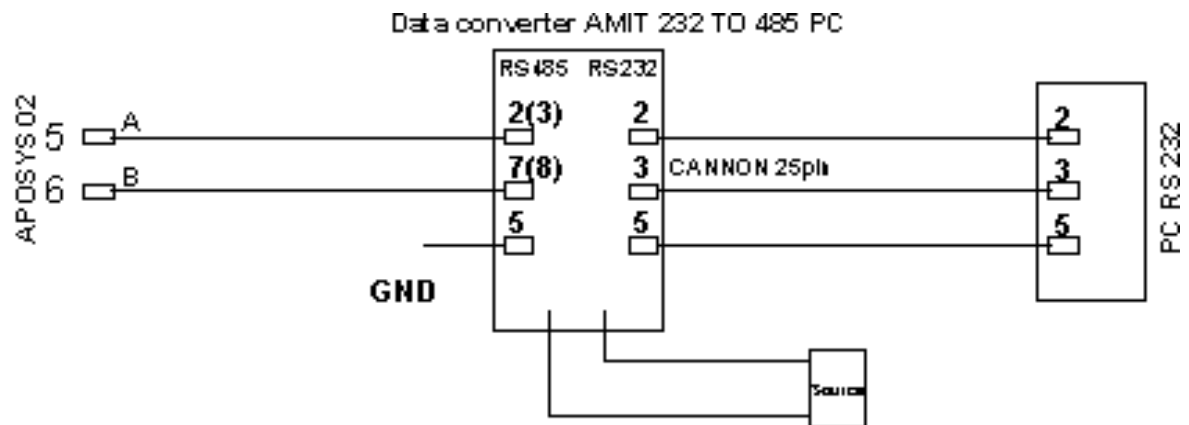

## 8. ES declaration of conformity

### ES DECLARATION OF CONFORMITY

We,

A.P.O. - ELMOS v.o.s., Pražská 90, 509 01 Nová Paka, Czech Republic  
IČO: 60111615

declare on our exclusive responsibility that below mentioned product meet a technical rule requirements that the product is at ours designate application condition secure and that we have taken steps by which we guarantee a conformity of all products below mentioned type be given on market with technical documentation and with requirements of corresponding decree of the government and European guidelines.

**Product:** Display apparatus **APOSYS 02**

**Type:** **APOSYS 02**

**Producer:** A.P.O. - ELMOS v.o.s.  
Pražská 90  
509 01 Nová Paka  
Czech Republic

The product is determined for measuring and control of temperature or the other values.

The product conformity review is made within its borders of the system of product quality review in the company by the authorized person (nr. AO 201, Elektrotechnický zkušební ústav, Pod lisem 129, Praha 8 – Troja) and execution of inspection over his correct function.

Above mentioned product is with conformity with norms

**electric security:**

ČSN EN 61010-1: 2003 including amendment EN 61010-1:2001 including amendment

**EMC:**

ČSN EN 61000-6-3: 2002 including amendment EN 61000-6-3: 2001 including amendment

ČSN EN 61000-6-2 ed.2: 2002 including amendment EN 61000-6-2: 2001 including amendment

and decree of the government (European guidelines)

**electric security:**

nr. 17/2003 Sb. including amendment 73/23/EEC including amendment

**EMC:**

nr. 18/2003 Sb. including amendment 89/336/EEC including amendment

A sample revision achieve a authorized person nr. AO 201, Electrotechnical experimental institute, Pod lisem 129, Praha 8 - Troja, which issue for this product a Certificate nr. 1040416 from day 5.4.2004 and Protocol about test EMC nr. 4.800385-00 from day 20.4.1999.

The final double-number of the year when the produkt has been labeled with identification CE: 02

Place of issue: Nová Paka

Name: Ing. Libor Lukeš

Date of issue: 1.2.2005

Function: comp. director

**APŔELMOS**  
A.P.O. - ELMOS v.o.s.  
Pražská 90, 509 01 Nová Paka  
DIČ: CZ60111615

Stamp:

Signature:

  
.....

## 9. Certificate about the product assembly and quality

Intelligent display instrument APOSYS 02 prod. no.

88-04-08888

We acknowledge that the above mentioned product is complete. And the product answer to technical conditions and is good inspected and tested.

## 10. Guarantee conditions

The producer answers that his product has and will has characters appointed technical norms for appointed time. That is complete and without defects. The producer also answers for defects which a customer find out in the guarantee time and which he claim in the time. The basic conditions of guarantee is the controller using in this way as the above mentioned is in the using handbook.

The guarantee time is 36 months from the date of sale.

The guarantee is possible to apply at material defects or at bad function of the product. Guarantee repairs are achieved with the guarantee rule of the company A.P.O.-ELMOS in the place of business.

The guarantee is dissolved as long as on the product were arrangements achieved or guarantee labels were break down and as long as the product were violently mechanical damage or with wrong using.

Guarantee and after guarantee service perform entirely A.P.O. – ELMOS.

Date of sale: .....

Signature: .....

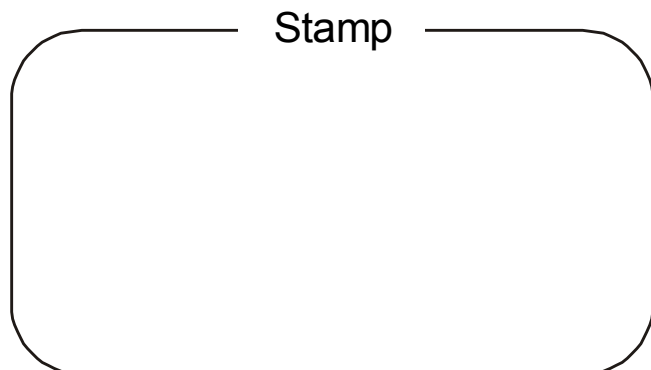

# Contents

<b>1. INTRODUCTION</b>	<b>3</b>
<b>2. DESCRIPTION</b>	<b>3</b>
2.1 FRONT PANEL	3
2.2 INPUT PART	4
2.3 OUTPUT PART	4
2.4 SIGNALLING	4
2.5 TECHNICAL DATES	5
2.6 DIMENSIONS	7
2.7 MOUNTING INSTRUCTIONS	7
2.8 APPARATUS CONNECTING	7
2.9 CONNECTING OF TERMINAL BLOCK	8
2.10 MEASURE RANGES OF INPUTS QUANTITIES	9
2.11 INNER INPUTS CONNECTING	9
2.12 EXAMPLE OF THREEWIRES CURRENT SENSOR 4.. 20 MA CONNECTING	9
2.13 CONNECTING OF INTERFACE FIELD	10
<b>3. THE PROGRAMMING</b>	<b>11</b>
3.1 MEANING OF PARAMETERS	12
<b>4. PARAMETERS LIMIT VALUES</b>	<b>14</b>
<b>5. THE COMMUNICATION PROTOCOL DESCRIPTION</b>	<b>15</b>
<b>6. INSTRUCTIONS FOR SOFTWARE PA 02A INSTALLATION</b>	<b>26</b>
6.1 SOFTWARE APOELMOS APPLICATION	26
6.2 INSTALLATION PROCESSING:	26
6.3 PROGRAM PA 02A DESCRIPTION	26
<b>7. INTRODUCTION</b>	<b>26</b>
7.1.1 FIRST STARTUP	27
7.1.2 GRAPH SETTING	27
7.1.3 DATA RECORD SPEED SETTING	28
7.1.4 CONTROLLER PARAMETERS SETTING	28
7.1.5 CONTROLLER SET PARAMETERS SAVING	29
7.1.6 DATA RECORD STARTING	29
<b>7.2 APPARATUS CONNECTION WITH PC</b>	<b>30</b>

<b>8.</b>	<b><u>ES DECLARATION OF COMFORMITY</u></b>	<b>31</b>
<b>9.</b>	<b><u>CERTIFICATE ABOUT THE PRODUCT ASSEMBLY AND QUALITY</u></b>	<b>32</b>
<b>10.</b>	<b><u>GUARANTEE CONDITIONS</u></b>	<b>32</b>



