



The **ESD3** electronic switch series are double state controllers operated by a microprocessor displaying the temperature measured on a three position LCD using 4 push buttons that are accessible, through a detachable transparent lid, for the setting of the values. The output signal (ON or OFF) is dependent on the instant temperature value measured and the preset values. Two switches are located on one board with one common input, together with one emergency switch with its own input. The output terminates in a relay with switching contacts for 240 V AC and a current load of 10A. The other two switches terminate in relays with switching contact for 240 VAC and 8A. Closed relays are confirmed by the green LEDs. The emergency switch is indicated by a red relay when switched off. The relay remains closed until unblocked when the supply voltage is interrupted and the RESET push button is depressed, provided that the temperature on the emergency sensor remains below the set value. The device is equipped with an automatic detector for defects in the circuit of temperature sensors. Should there be a defect in any of the circuits (O/C or S/C), the display will show **Er1** (emergency T1) or **Er2** (T2, T3) and all relays will be switched to a position corresponding to the supply voltage being switched off. When the defect will be rectified, the device will become operational again when the key ↵ is depressed.

Main technical parameters

Display range	-99 ÷ 999	
Display resolution	-99°C to -10°C / -9,9°C to 99,9°C / 100°C to 999°C	
Accuracy of measurement	Sensor error (standard class B), ± 1 digit	
Sampling frequency	typical 300 ms	
Range of measured temperatures	Limited by the type of the temperature sensor used: -stem length 370 mm with duralumin center holder : -50 ÷ 150 °C -sensor with cable output type SK2PA-LT: -50 ÷ 350 °C -any external sensor with twin conductor connection to the sensor Ni1000/6180ppm, Ni1000/5000ppm, Pt100/3850ppm, Pt1000/3850ppm: according to type	
Push button "RESET"	-located on the bottom of the box next to the cable glands -the remote push button can be connected to the terminal board RESET	
Supply voltage	ESD3/230 ESD3/24AC	230 V/50Hz 24 VAC ± 10% 24 VDC ± 20%
Maximum switched voltage	T1 (emergency)	T2, T3
Maximum switched current	240 VAC 10 A switching contacts	240 VAC 8 A switching contacts
Degree of protection	IP54	
Ambient temperature - operational	-25 to 50 °C	
Ambient temperature - storage	-25 to 80 °C	
Relative humidity	< 70%	
Connection	Bus bar COB5, wire cross section 2,5 mm ² maximum	
Material for sensor – stem length 370 mm	Stainless steel DIN 1.4301 (17248), center holder, duralumin material	

Setup menu

126 Measured temperature Press \downarrow to enter setup menu

- | | |
|--------------------------------------------|-----------------------------------------------------------------------------------------------------------------------------------------------------------------------------------------------------------------------------------------------------------------------------------------------------------------------------------------------------------------------------------------------------------------------------------------------------------------------|
| tP1 Set temperature T1 | <ul style="list-style-type: none"> \downarrow - enter set temperature in °C for switch T1 (emergency) \downarrow - set value of the actual flashing number \rightarrow - move to the next number \downarrow - confirm change and move to the next line on the menu, ESC - no change |
| tP2 Set temperature T2 | <ul style="list-style-type: none"> \downarrow - enter set temperature in °C for switch T2 \downarrow - set value of the actual flashing number \rightarrow - move to the next number \downarrow - confirm change and move to the next line on the menu, ESC - no change |
| tP3 Set temperature T3 | <ul style="list-style-type: none"> \downarrow - enter set temperature in °C for switch T3 \downarrow - set value of the actual flashing number \rightarrow - move to the next number \downarrow - confirm change and move to the next line on the menu, ESC - no change |
| Ind Choice of input for the display | <ul style="list-style-type: none"> \downarrow - entry to input of displayed measured temperature: \rightarrow - switch between t1 - sensor of emergency switcher
t23 - T1 and T2 sensor switch \downarrow - confirm change and move to the next line on the menu, ESC - no change |
| HES Password for the 2nd level | <ul style="list-style-type: none"> \downarrow - entry for setting password 111 \downarrow - set value of the actual flashing number \rightarrow - move to the next number \downarrow - confirm change and move to the next line on the menu, ESC - no change |
| ou1 Heating/Cooling modes T1 | <ul style="list-style-type: none"> \downarrow - entry to set up of T1 mode: \rightarrow - switch between OH - "heating" mode
CHL - "cooling" mode \downarrow - confirm change and move to the next line on the menu, ESC - no change |
| ou2 Heating/Cooling modes T2 | <ul style="list-style-type: none"> \downarrow - entry to set up of T2 mode: \rightarrow - switch between OH - "heating" mode
CHL - "cooling" mode \downarrow - confirm change and move to the next line on the menu, ESC - no change |
| ou3 Heating/Cooling modes T3 | <ul style="list-style-type: none"> \downarrow - entry to set up of T3 mode: \rightarrow - switch between OH - "heating" mode
CHL - "cooling" mode \downarrow - confirm change and move to the next line on the menu, ESC - no change |
| HY1 Hysteresis T1 | <ul style="list-style-type: none"> \downarrow - confirm change and move to the next line on the menu, ESC - no change \downarrow - entry to setup of hysteresis T1: \downarrow - set value of the actual flashing number \rightarrow - move to the next number \downarrow - confirm change and move to the next line on the menu, ESC - no change |
| HY2 Hysteresis T2 | <ul style="list-style-type: none"> \downarrow - entry to setup of hysteresis T2: \downarrow - set value of the actual flashing number \rightarrow - move to the next number \downarrow - confirm change and move to the next line on the menu, ESC - no change |
| HY3 Hysteresis T3 | <ul style="list-style-type: none"> \downarrow - entry to setup of hysteresis T3: \downarrow - set value of the actual flashing number \rightarrow - move to the next number \downarrow - confirm change and move to the next line on the menu, ESC - no change |

Mode "heating" : sensor temperature < set temperature = relay on ; sensor temperature > set temperature = relay off

Mode "cooling" : sensor temperature > set temperature = relay on ; sensor temperature < set temperature = relay off

Wiring schematic

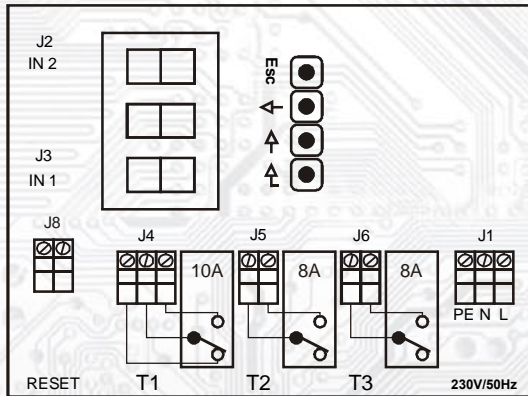

The relay contacts are illustrated in the still-stand position, which corresponds to the supply voltage switching off.

Terminal board J1 serves for the connection of power.
Terminal board J8 serves for the connection of an external push button for the unblocking of the T1 emergency switch.

Terminal board J3 serves for the connection of the external signal of the T1 emergency switch.

Terminal board J2 serves for the connection of the external signal of the T1, T2 switches.

Contacts of the T1 relay emergency switch are connected to terminal board J4.

Contacts of the T2 relay switch T2 are connected to terminal board J5.

Contacts of the T3 relay switch T3 are connected to terminal board J6.

Keys ESC, ↓, →, ↵ are used when programming the switch.

Exact definition of real comparative set temperature

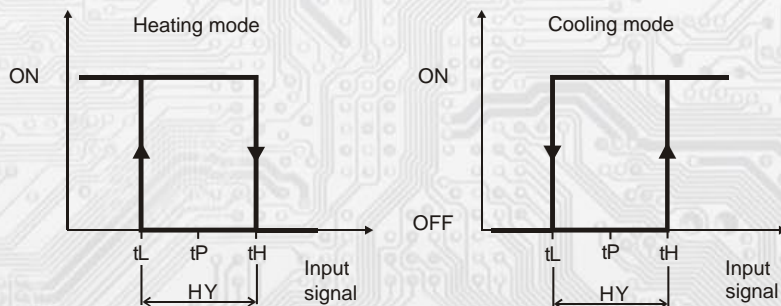

The set upper and lower temperature is given by:

$$tL = tP - (HY / 2) \text{ [}^\circ\text{C]} \quad tH = tP + (HY / 2) \text{ [}^\circ\text{C]}$$

Where: tL is the low set temperature
 tH is the upper set temperature
 tP is the set comparative temperature
 HY is the set hysteresis

For actual values : $tP = 100^\circ\text{C}$, $HY = 10^\circ\text{C}$
the results will be $tL = 95^\circ\text{C}$ and $tH = 105^\circ\text{C}$

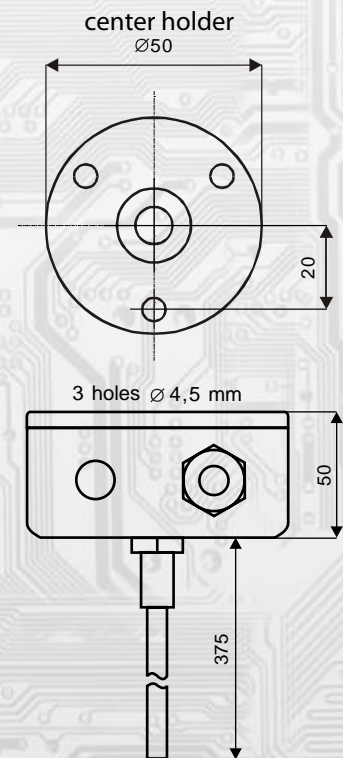

Factory configuration ESD3J

Temperature	Regime OH/CH	Hysteresis
tP1 110°C	Ou1 OH	HY1 02
tP2 80°C	Ou2 OH	HY2 10
tP3 50°C	Ou3 CH	HY3 15

T1 wrecking crane regime ON/OFF
t1.H ON

Function only for ESD3J	
For a period of: Disp. – Er.r	T3 ON
<i>HEED!! This state depends on setting tP3 plus achieved temperature. Request firm Jinova.</i>	

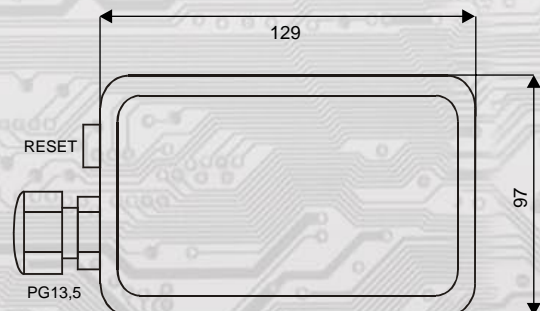

Order sample:

5 pcs. of ESD3/230 electronic switch
Temperature sensor: stem length 370 mm with center holder,
Push RESET button on the box with available connection to an external push button.