



- Simple level switch with single control position
- Simple level switch with double control position
- Two independent level switches with single control position
- DIP function selection (inflow, outflow, quantity supervision)
- Adjustable time delay of ON and OFF
- Adjustable sensitivity (fluid resistance)

The RH1 level switch has been designed to control the levels of electrically conductive fluids. Basically, it is the function for measuring resistance between sensors. In metal tanks the common sensor can be replaced by the tank wall. The usage of AC current prevents the formation of electrochemical corrosion of the sensors and the electrolysis of the fluids. The signal frequency of 185 Hz and installed filters improve the immunity against the power supply frequency interference. Depending on the setting of the DIP switches, two separate levels or the minimum-maximum levels in one tank can be controlled (see diagram showing the specific functions).

The switch-on point can be adjusted in the range between 5 k Ω and 100 k Ω . The delay can be adjusted in each sensor between 1 and 10 sec, and using the DIP also switches the delay type (relay closes or opens).

Max. power input	3,5 VA	1,5 VA	1,5W
Accuracy of power input	$\pm 10\%$		
Sensitivity (input resistance)	adjustable between 5 k Ω and 100 k Ω		
Voltage between electrodes	4,5 V / 185 Hz		
Max. current between sensors	0,1 mA AC		
Max capacitance between cables	5 nF		
Time delay tD:	adjustable between 1sec and 10 sec		
Time delay tH:	adjustable between 1sec and 10 sec		
Delay during switching on	12 sec		
Output	2 x repositioning relay 6 A / 250 V AC		
Safety cover of terminals	IP20		
Installation	DIN board 35 mm		

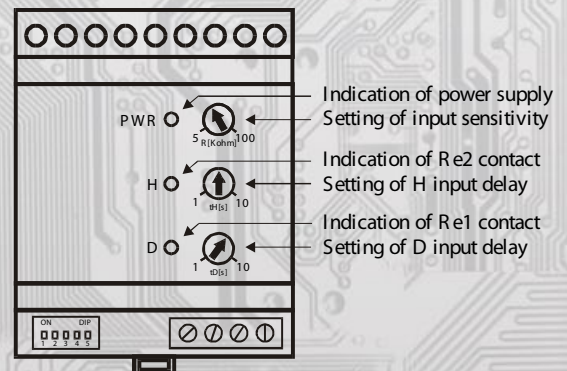

Measuring probes

Any sensors that enable conductive contact an surface can be used. Conductors of particular probes needn't be shielded but it is recommended. Shielding joins the clamp GND.

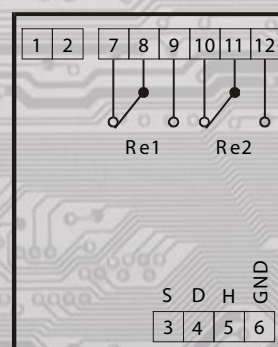

- 1,2 – contact to power supply
- 3 - S - contact to common sensor
- 4 - contact to D sensor
- 5 - contact to H sensor
- 6 - screen attachment
- 7,8,9 – switching contacts Re1
- 10,11,12 – switching contacts Re2

Functions

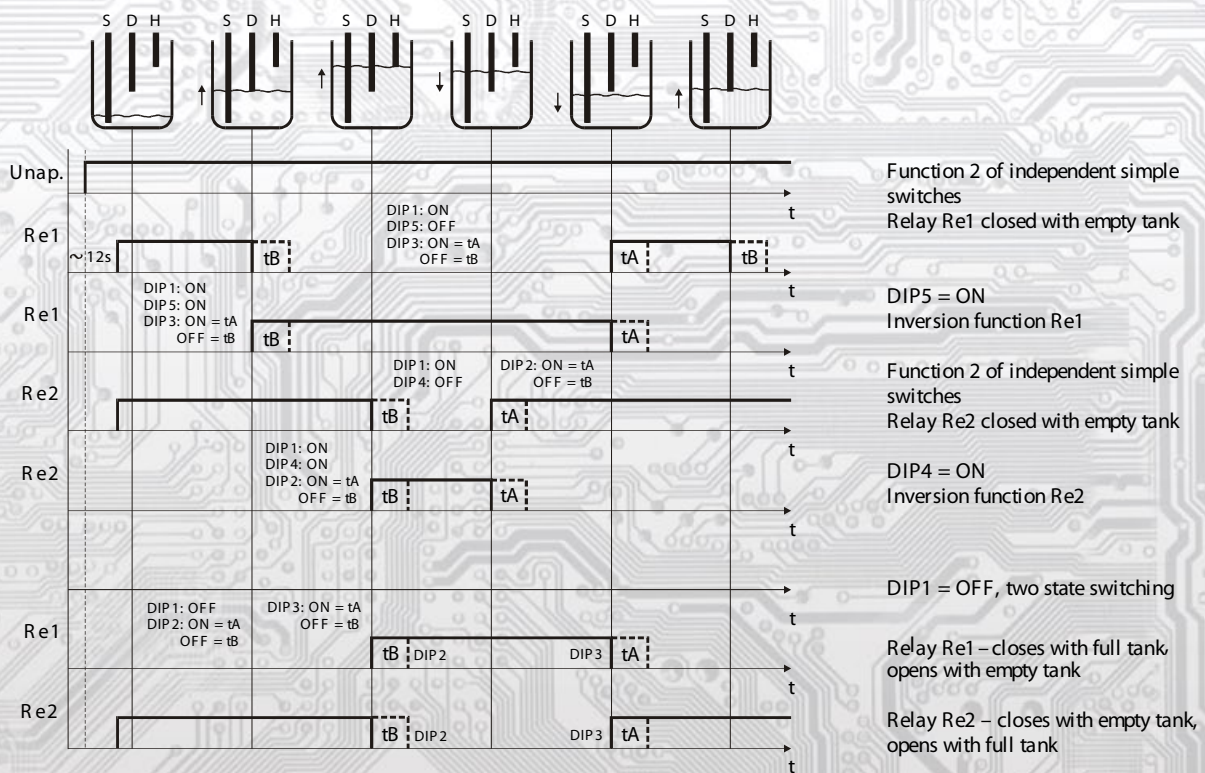

Settings of the DIP switch

The DIP switch is accessible when the bottom cover of the terminal board is removed.

- DIP 1: ON = 1x (single switch)
- DIP 1: OFF = 2x (double switch)
- DIP 2: ON = DELAY tA (UPPER SENSOR)
- DIP 2: OFF = DELAY tB (UPPER SENSOR)
- DIP 3: ON = DELAY tA (BOTTOM SENSOR)
- DIP 3: OFF = DELAY tB (BOTTOM SENSOR)
- DIP 4: ON = INVERSION FUNCTION Re2 (UPPER SENSOR)
- DIP 5: ON = INVERSION FUNCTION Re1 (BOTTOM SENSOR)
- DIP 4,5 are activated only when DIP 1 = ON

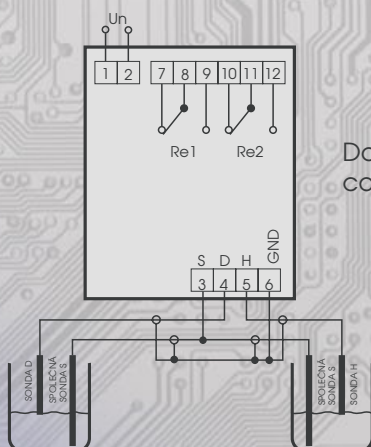

Double channel control

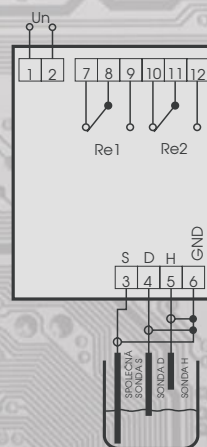

Single channel control (min., max.)