

### Description:

The resistance temperature sensors are designed for general - purpose application in control and regulation systems for the temperature measurement in the pipeline in systems with high demands on speed of response. The temperature element is located in the stem. The head of sensor is made of aluminium, material of the stem is stainless steel (DIN 1.4601). Standard version is made to maximal temperature 120°C.

### Technical parameters:

Measuring range	-30 ÷ 250 °C (Pt100, Pt500, Pt1000) -30 ÷ 200 °C (Ni1000, Ni10000, Ni891, Ni2226) -30 ÷ 150 °C (NTC 20kΩ)
Sensin element	see the table below
Connection	2 (on request 3 or 4) wiring
Accuracy	class B, IEC 751 (Pt100, Pt 500, Pt1000) class B, DIN 43760 (Ni1000, Ni10000, Ni891, Ni2226) ± 1 °C (NTC20kΩ)
Head	material aluminium, color grey
Stem	stainless steel, DIN 1.4301, Ø = 6 mm, length of stem L1: see the table below
Insulation resistance	> 100 MΩ at 25 °C (500 V DC)
Protection type	IP 65 (EN 60529)
Relative humidity	< 95 %
Terminal board	ceramic, tape KLM
Cable gland	PG9, wire diameter 4 ÷ 8 mm
Versions	P16x - L1 (one sensing element) 2P16x - L1 (two sensing elements) x = P,PA, PB, S, L, J, SA, H or N

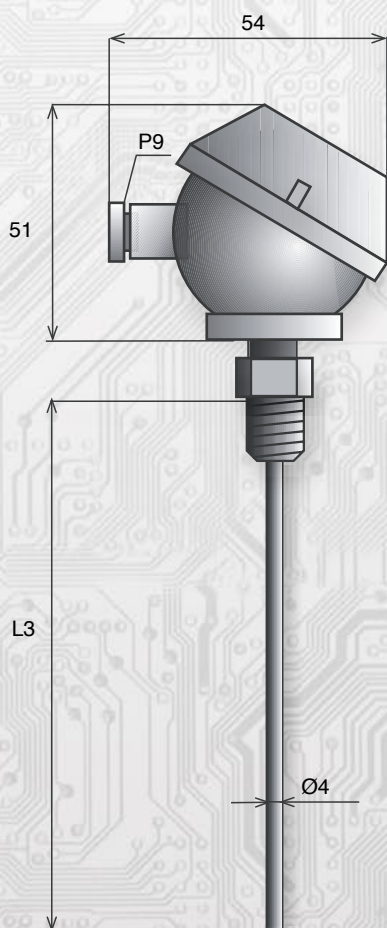

length of the sensor

L3 (mm)
100
160

Wiring

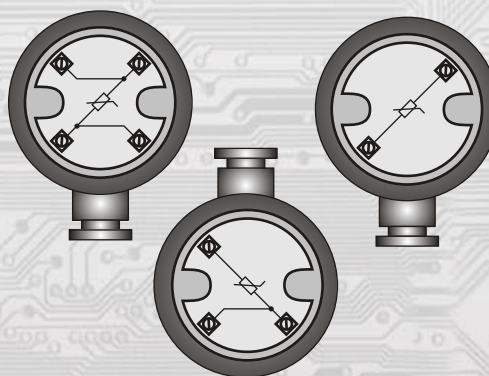

### Summary

Sensor	A16P	A16PA	A16PB	A16S	A16L	A16J	A16SA	A16H	A16N
Sensing element	Pt100	Pt1000	Pt500	Ni1000/6180	Ni1000/5000	Ni891	Ni10000/6180	NTC 20kΩ	Ni2226
Recommended measurement current	1 mA	0,1 mA	0,7 mA	0,1 mA	0,1 mA	0,1 mA	0,01 mA	*	0,1 mA
Max. measurement current	5mA	1 mA	3 mA	1 mA	1 mA	1 mA	0,5 mA	*	0,7 mA