

- frequency output 1Hz - 20kHz
- sensor configuration by MBSet program
- Modbus RTU communication over RS485 line

The temperature sensors are intended for general-purpose application in control and regulation systems for the temperature measurement in airflows, in outside, in the pipeline.

The head of sensor is made of the polycarbonat, cover is provided with quick-locking screws, the stem is made of stainless steel (DIN1.4301).

### Arrangement of jumpers and connectors

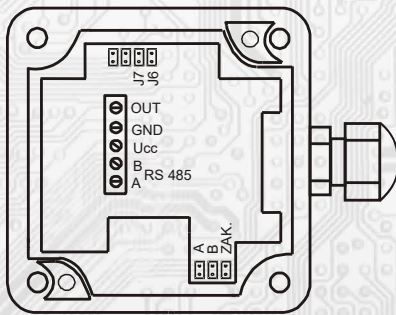

- A...definition of idle status (conductor A)
- B...definition of idle status (conductor B)
- ZAK...termination resistor 120R
- J6...jumper "service" - enabling writing the configuration value
- J7...jumper "service" (setting a fixed address 255 and setup communication speed of 19200 baud)

- Terminals A, B .....RS485
- Terminal Ucc.....power supply
- Terminal GND.....common terminal
- Terminal OUT...frequency output

### Technical data

Supply voltage	12 to 30 VDC
Current consumption	max. 40mA (Rz = 10 kΩ)
Measuring range	-50 to 200°C
P14F	-50 to 120°C
P10F, P11F	-30 to 50°C
P18F (cable sensor Pt1000)	-50 to 400°C
Ambient temperature	-30 to 50°C
Relative humidity	< 80 %
Accuracy	± 0,5 °C
Time needed for equalization (P10F)	30 min.
Communication	RS485, protocol Modbus RTU
Configuration software	REGMET MBSet; www.regmet.cz
Communication speed	1200 ÷ 19200 Bd
Range of output frequency	1Hz ÷ 20kHz
Protection type	IP65
P10F	IP30
Terminal board	COB (wires max. 1,5 mm <sup>2</sup> )
Terminal board (P18F)	CPP(wires max. 0,75 mm <sup>2</sup> )
Cable gland	PG9 / 8 mm

### Summary

Interior	<b>P10F</b>
Outdoor Air	<b>P11F</b>
Duct probe	<b>P12F-L1</b>
Well insertion probe	<b>P13F-L2</b>
Strap-mount	<b>P14F</b>
Quick-action	<b>P16F-L3</b>
Cable type	<b>P18F</b>

### Standard length L1 and L2

L1 (mm)	L2 (mm)	L3 (mm)
120	100	100
180	160	160
240	220	
300	280	
360	340	

### Max. operation temperature

P10, P11	80 °C
P14, P16	120 °C
P12, P13	250 °C

### Example of wiring the controllers in the system:

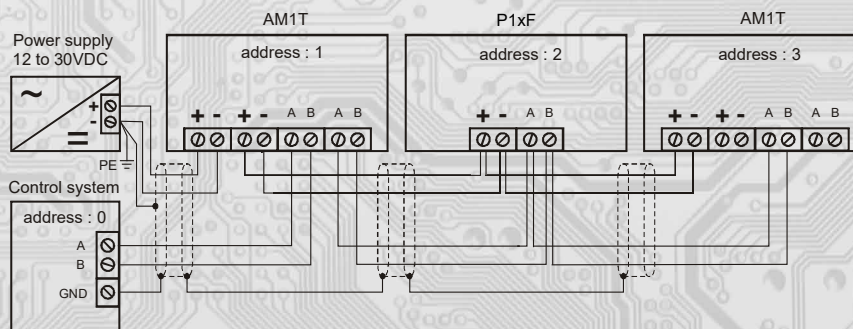

\*\* During the transfer the addresses of registers are indexed from zero, i.e. register 0x0001 is physically sent through the bus bar as 0x0000... (zero based addressing).

### Temperature measurement:

- is conducted over a resistive sensor Pt1000. The sensor is built into the stem and connected to the circuit board by means of a loose lead and connectors. The input signal is evaluated by the electronics, which converts this value to the PWM output signal as per the parameters set in EXTENDED REGISTERS - **Map X RAM (EXTENDED REGISTERS)**.

The current temperature value is sent over the RS485 line in the form of a 16-bit number with a signed integer multiplied by a constant 10.

**Register 0 x0005 \*\* (measurement temperature): 0xFE0C; 65036dek (-50°C) 0x07D0; 2000dek (200°C).**

The parameters are set in configuration window of program REGMET MBSset or by other program with communication ModBus RTU.

### SW configuration of sensor using the REGMET MBSset program:

The configuration application REGMET MBSset is freely available at producer's web pages. The controlled can be configured only when the jumper J6 is inserted before the connection of supply voltage (reset) and J7 jumper (setting the fixed sensor address to 255 and setting the baudrate to 19 200 Bd - these network variables are reserved for configuration only and, therefore, if the required sensor address of 255 is set, the sensor modifies to 254 automatically) are inserted. In case only the J7 jumper is inserted, it is possible to use a fixed address and baudrate without the risk of overwriting the configuration parameters.

After the launching of REGMET MBSset program, the basic window is opened and the connected sensor is automatically connected with the hosting PC.

After running the REGMET MBSset application, the basic window opens, which allows general setup of the application. First, in Nastavení (Settings)→Sériový přenos (Serial transfer), select the port to which the RS485 communication interface is connected.

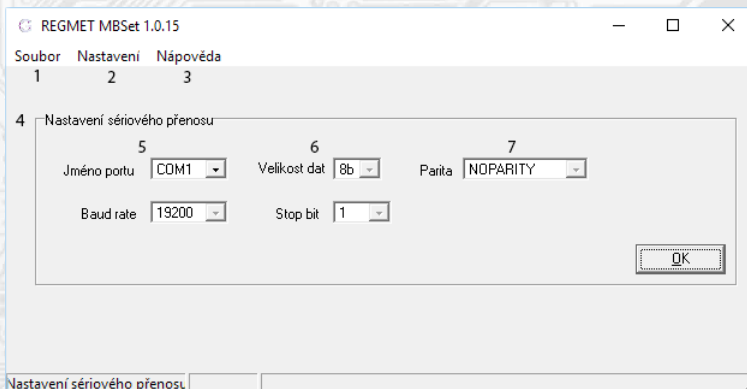

1. Soubor.....File
2. Nastavení.....Setting
3. Nápověda.....Help
4. Nastavení sériového přenosu...Serial transmission setting
5. Jméno portu...Port name
6. Velikost dat....data size
7. Parita...Parite

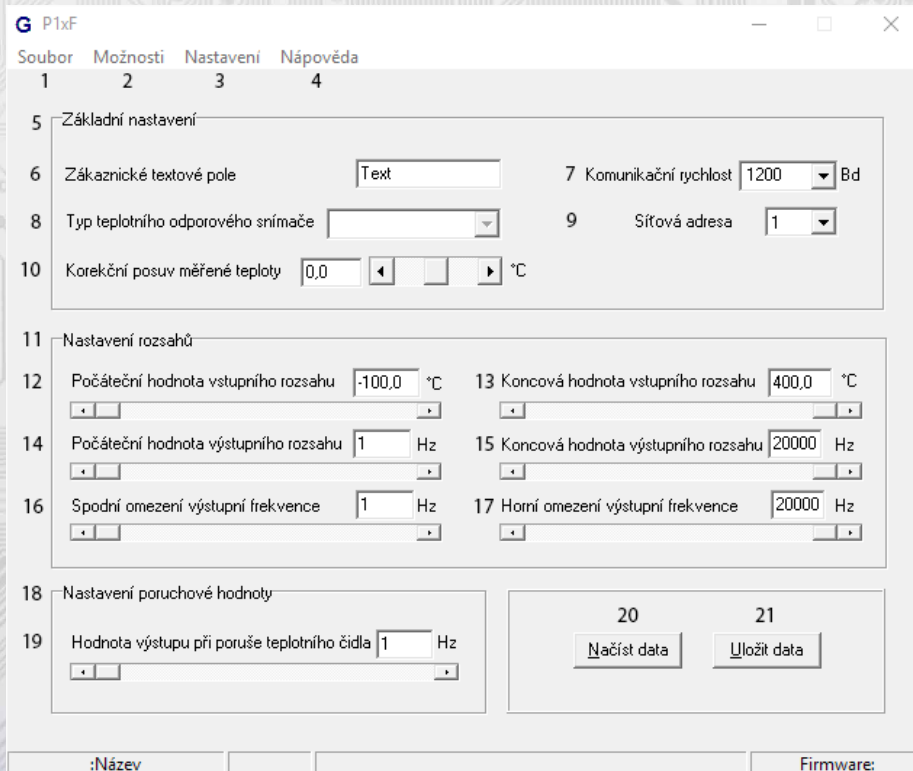

Translate:

1. Soubor.....File
2. Možnosti.....Options
3. Nastavení.....Setting
4. Návod.....Help
5. Základní nastavení...Basic setting
6. Zákaznické textové pole.....The custom text field (ZD-TEXT)
7. Komunikační rychlost.....Baud rate (SK-SPD)
8. Temperature sensor (ZD\_INT)
9. Síťová adresa.....Network address (SK\_ADR)
10. Korekční posuv měřených teplot..... Correction of temperature (ZD\_OFF)
11. Nastavení rozsahů.....ranges setting
12. Počáteční hodnota vstupního rozsahu.....Initial value of the input temperature range (AU-I1)
13. Koncová hodnota vstupního rozsahu...Ended value of the Input temperature range. (AU\_I2)
14. Počáteční hodnota výstupního rozsahu.....Initial value of the output frequency range (AU\_O1)
15. Koncová hodnota výstupního rozsahu.....Ended value of the output frequency range AU\_O2)
16. Spodní omezení výstupní frekvence.....Bottom stop value of the output frequency (AU\_FL)
17. Horní omezení výstupní frekvence...The upper limit value of the output frequency (AU\_FH)
18. Nastavení poruchové hodnoty...Fault setting
19. Hodnota výstupu při poruše čidla...Output value in case of fault of the temperature probe (AU\_SP)
20. Načíst data...Load data
21. Uložit data.....Save data

### Mapa X RAM (EXTENDED REGISTERS):

EXTENDED REGISTERS can only be modified if the J6 jumper (enabling writing the configuration values) and J7 jumper (setting the fixed sensor address to 255 and setting the baudrate to 19 200 Bd - these network variables are reserved for configuration only and, therefore, if the required sensor address of 255 is set, the sensor modifies to 254 automatically) are inserted. In case only the J7 jumper is inserted, it is possible to use a fixed address and baudrate without the risk of overwriting the configuration parameters. The configuration is carried out by **command 16** (multiple register preset 0x10). The changes are written and configuration is finished by extracting the J6 and J7 jumpers. No reset is necessary for proper function.

X Reg = 8 byte, ie 4 registers MODBUS

	range of adres X Reg **	
X Reg	[hex]	[dek]
X Reg 0	0x2001 ÷ 0x2004	8193 ÷ 8196
X Reg 1	0x2005 ÷ 0x2008	8197 ÷ 8200
X Reg 2	0x2009 ÷ 0x200C	8201 ÷ 8204
X Reg 3	0x200D ÷ 0x2010	8205 ÷ 8208

	Obsah X Reg							
X Reg	Byte 0	Byte 1	Byte 2	Byte 3	Byte 4	Byte 5	Byte 6	Byte 7
X Reg 0	-	-	ZD_TEXT/0	ZD_TEXT/1	ZD_TEXT/2	ZD_TEXT/3	ZD_TEXT/4	ZD_TEXT/5
X Reg 1	ZD_TEXT/6	ZD_TEXT/7	ZD_TEXT/8	ZD_TEXT/9	-	ZD_INT	ZD_OFF/Hi	ZD_OFF/Lo
X Reg 2	SK_ADR	SK_SPD	AU_I1/Hi	AU_I1/Lo	AU_I2/Hi	AU_I2/Lo	AU_O1/Hi	AU_O1/Lo
X Reg 3	AU_O2/Hi	AU_O2/Lo	AU_SP/Hi	AU_SP/Lo	AU_FL/Hi	AU_FL/Lo	AU_FH/Hi	AU_FH/Lo

**ZD\_TEXT** The custom text field, range is 10 bytes. It is determined for the client's identification of the device.

**ZD\_INT** Type of temperature sensor, The range is 1 byte. Takes the value 0 to 255. The number format is 16-bit unsigned integer

value ZD_INT [hex]	0x00	0x01	0x02
value ZD_INT [dek]	0	1	2
type of sensor	Ni 1000/5000ppm	Ni 1000/6180ppm	Pt 1000/3850ppm

**ZD\_OFF** Correction of temperature. Range is 2 bytes, form of number with sign (signed integer) multiplied by the constant 10. 0x0001 = 0,1°C, 0xFFFF = -0,1°C..

**SK\_ADR** Network address. range is 1 byte. It acquires the values 0 ÷ 255 dek, whereas the address 0 is reserved for the broadcast and the sensor does not respond to it, the address 255 is reserved for the controller configuration. Thus the range of available addresses is 1 ÷ 254. The number format is unsigned integer.

**SK\_SPD** Baud rate. range is 1 byte, It acquires the values 0 ÷ 4. The number format is unsigned integer.

value SK_SPD [hex]	0x00	0x01	0x02	0x03	0x04
value SK_SPD [dek]	0	1	2	3	4
speed [Bd]	1200	2400	4800	9600	19200

**AU-I1:** Initial value of the input temperature range. It acquires the values -3276,7 to 3276,6°C. Range is 2 bytes, form of number with sign (signed integer) multiplied by the constant 10. 0x0001 = 0,1°C, 0xFFFF = -0,1°C.

**AU-I2:** Ended value of the Input temperature range. It acquires the values -3276,7 to 3276,6°C. Range is 2 bytes, form of number with sign (signed integer) multiplied by the constant 10. 0x0001 = 0,1°C, 0xFFFF = -0,1°C.

**AU-O1:** Initial value of the output Frequency range. Range is 2 bytes, form of number - unsigned integer.. It acquires the values 0x0001 = 1Hz to 0x4E20 = 20kHz

**AU-I2:** Ended value of the Output Frequency range... Range is 2 bytes, form of number - unsigned integer.. It acquires the values 0x0001 = 1Hz to 0x4E20 = 20kHz

**AU-SP:** Output value in case of fault of the temperature probe. It acquires the values 0x0001 = 1Hz to 0x4E20 = 20kHz. Range is 2 bytes, form of number - unsigned integer.

**AU-FL:** Bottom stop value of the output frequency when the input range is undercurrent. It acquires the values 0x0001 = 1Hz to 0x4E20 = 20kHz. Range is 2 bytes, form of number - unsigned integer.

**AU-FH:** The upper limit value of the output frequency for overflow of the input range. It acquires the values 0x0001 = 1Hz to 0x4E20 = 20kHz. Range is 2 bytes, form of number - unsigned integer.

\*\* During the transfer the register addresses are indexed from zero, i.e. register 0x2001 is physically sent through the busbar as 0x2000... (zero based addressing)

Description of configuration values (in the bracketing is the name of the byte of the appropriate registry for setting the sensor using other software than REGMET MBSer - see X RAM map)

### Examples of communication:

Command 03 (0x03): Read Holding Registers:

Master: 02 03 00 00 00 01 Crc Crc  
 ↳ ↳ ↳ ↳ ↳ Number of read registers (1 registers)  
 ↳ ↳ ↳ ↳ ↳ Address of initially read register (0x0001\*\*)  
 ↳ ↳ ↳ ↳ ↳ Command (Read Holding Registers)  
 ↳ ↳ ↳ ↳ ↳ Address of device (device with address 2)

Slave: 02 03 06 00 FF Crc Crc  
 ↳ ↳ ↳ ↳ ↳ Data from register (0x00FF)  
 ↳ ↳ ↳ ↳ ↳ Number of bytes (2)  
 ↳ ↳ ↳ ↳ ↳ Command (Read Holding Registers)  
 ↳ ↳ ↳ ↳ ↳ Address of device (device with address 2)

The address of initial register is 0x0001 \*\* which is the address of measured temperature register.

Thus: the measured temperature 0x00FF = 25,5° C.

Command 16 (0x10) Write Multiple Registers:

Master: FF 10 20 08 00 01 02 09 04 Crc Crc  
 ↳ ↳ ↳ ↳ ↳ Registered data (0x0904)  
 ↳ ↳ ↳ ↳ ↳ Number of bytes (2)  
 ↳ ↳ ↳ ↳ ↳ Number of registered registers (1)  
 ↳ ↳ ↳ ↳ ↳ Address of first registered register (0x2009\*\*)  
 ↳ ↳ ↳ ↳ ↳ Command (Preset Multiple Registers)  
 ↳ ↳ ↳ ↳ ↳ Address of device (with inserted jumper "service" J6 - address 255)

Slave: FF 10 20 08 00 01 Crc Crc  
 ↳ ↳ ↳ ↳ ↳ Number of registered registers (1)  
 ↳ ↳ ↳ ↳ ↳ Address of first registered register (0x2009\*\*)  
 ↳ ↳ ↳ ↳ ↳ Command (Preset Multiple Registers)  
 ↳ ↳ ↳ ↳ ↳ Address of device (with inserted jumper "service" J6 - address 255)

With writing of the value 0x0904 in register 0x2009\*\* the address 9 is set and the Baud rate 19 200 Bd is set.

### Technical description, execution

- P10F** sensors for temperature measuring in interior applications.
- P11F** sensors are designed for temperature measuring of outdoor air. They are provided with a plastics console for attaching to a wall; the actual sensing element is positioned in a stainless steel stem of 25mm length; the terminal board for connecting is positioned in a plastics head.
- P12F-L1** sensor execution for mounting into air conditioning ducts. With the exception of the console, the execution is identical with P11x; L1 denotes the shank length specified in millimeters, for example P12L-120 is a conventional sensor with stemlength of 120 mm.
- P13F-L2** the sensors are designed for measuring operations in pipelines. As an accessory a part of the sensor is a stainless steel well fitted with a thread G 1/2: of length L2 mm, which was tested for pressure of 4,0 MPa.
- P14F** strap-mount sensors
- P16F-L3** quick-response type of sensors: stem length L3 = 100 or 160 mm.

### Dimensions and accessories

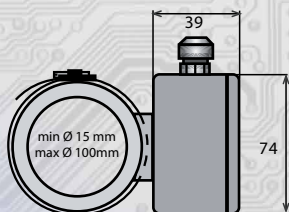
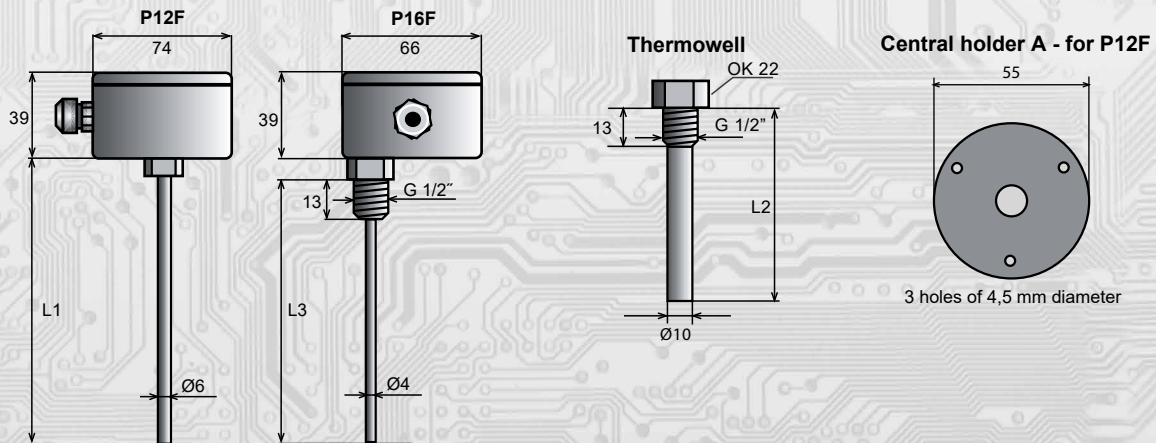

Maximum temperature of the surface measured  
 $t_p < 120^{\circ}\text{C}$

### Side holder A - for P11F

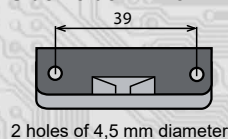

### Wall Mount- P10F

